

Contact Info: Office: 309.756.0955

Fax: 309.756.0957

sales@tmsvacuum.com

See Through Inlet Vacuum Filters

ST Series "T" Style

2" to 4" FPT Connections



- Easy Maintenance Checks
- In-Stock
- Vacuum Tested
- Save Costs
- For CT 2", 2-1/2", 3", & 4" Connections

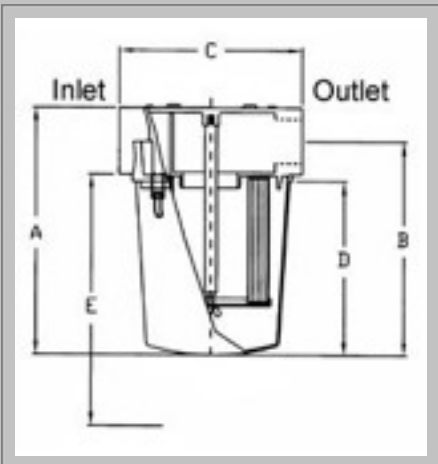

BENEFITS

- ♦ Maintenance checks are simplified with visual inspections
- ♦ Reduce downtime by eliminating need to shut down system to check filter
- ♦ Tested to withstand impacts and fractures at full vacuum
- ♦ Extended bucket for additional holding capacity
- ♦ Great for extreme duty applications
- ♦ High heat resistance for sterile environments

FEATURES & SPECS

- ♦ Bucket made from polycarbonate material
- ♦ **Vacuum level:** Typically 1x10⁻³ mmHg (1.3x10⁻³ mbar)
- ♦ High tensile strength permits dimensional stability
- ♦ Temperature Ratings:
 - Complete Assembly max: 220°F
 - See-Through bucket max: 290°F
- ♦ Increased holding capacity over carbon steel CT Series version
- ♦ **Compact** design for space restrictions; **Minimal** service area needed
- ♦ **Integrated Inlet Baffle**
- ♦ Inlet is above the element to **Extend** element life and maintenance intervals
- ♦ "T" style design **Minimizes** piping requirements
- ♦ "Drop-Down" housing for easy servicing and dirt containment

OPTIONS

- ♦ Pressure designs: T-bolt or J-hook configurations
- ♦ Low flow - high capacity configurations
- ♦ Extreme duty SpinMeister design
- ♦ 1/2" FPT drain port
- ♦ Epoxy coating on head piece
- ♦ Liquid Separator, STS Series model
- ♦ Stainless steel coating on head piece
- ♦ Heavy duty CT series (with carbon steel buckets) available 2" to 6" FPT connections

Model	FPT Inlet & Outlet	DIMENSIONS - inches					Nominal SCFM Rating	Holding Capacity Gal.
		A	B	C	D	E		
STS-200C	2"	16 1/4	14 1/4	9	12 1/2	22	175	1
STS-250C	2-1/2"	16 1/4	14 1/4	9	12 1/2	22	210	1
STS-300C	3"	19 3/4	17	13 1/2	14	25	300	2
STS-400C	4"	19 3/4	17	13 1/2	14	25	500	2